

EtherCAT Comm. Type 2-Phase Closed-loop Stepper Motor Driver



AiC-D-EC Series PRODUCT MANUAL

For your safety, read and follow the considerations written in the instruction manual, other manuals and Autonics website.

The specifications, dimensions, etc. are subject to change without notice for product improvement. Some models may be discontinued without notice.

Features

- Closed-loop system with real-time position control
- High speed & high torque drive without missing steps
- Multi-axis simultaneous control with EtherCAT communication
- Windows-based software (atMotion) for easy parameter setting and monitoring
- 7-segment display for alarm / status reading
- Built-in brake type motors available (AiC-D-B-EC Series)

Safety Considerations

- Observe all 'Safety Considerations' for safe and proper operation to avoid hazards.
- ⚠ symbol indicates caution due to special circumstances in which hazards may occur.

⚠ Warning Failure to follow instructions may result in serious injury or death.

- 01. Fail-safe device must be installed when using the unit with machinery that may cause serious injury or substantial economic loss. (e.g. nuclear power control, medical equipment, ships, vehicles, railways, aircraft, combustion apparatus, safety equipment, crime / disaster prevention devices, etc.)**
Failure to follow this instruction may result in personal injury, economic loss or fire.
- 02. Do not use the unit in the place where flammable / explosive / corrosive gas, high humidity, direct sunlight, radiant heat, vibration, impact or salinity may be present.**
Failure to follow this instruction may result in explosion or fire.
- 03. Do not connect, repair, or inspect the unit while connected to a power source.**
Failure to follow this instruction may result in fire or electric shock.
- 04. Install the unit after considering counter plan against power failure.**
Failure to follow this instruction may result in personal injury, economic loss or fire.
- 05. Check 'Connections' before wiring.**
Failure to follow this instruction may result in fire.
- 06. Do not disassemble or modify the unit.**
Failure to follow this instruction may result in fire or electric shock.
- 07. Install the driver in the housing or ground it.**
Failure to follow this instruction may result in personal injury, fire or electronic shock.
- 08. Do not touch the unit during or after operation for a while.**
Failure to follow this instruction may result in burn or electric shock due to high temperature of the surface.
- 09. Emergency stop directly when error occurs.**
Failure to follow this instruction may result in personal injury or fire.

⚠ Caution Failure to follow instructions may result in injury or product damage.

- 01. When connecting the power input, use AWG18 (0.75 mm²) cable or over.**
- 02. Brake is non-polar. When connecting the brake, use AWG24 (0.2 mm²) cable or over.**
Failure to follow this instruction may result in fire or malfunction due to contact failure.
- 03. To use the motor safely, do not apply external force to the motor.**
- 04. It is recommended to use STOPPER for the vertical load.**
- 05. Install over-current prevention device (e.g. the current breaker, etc.) to connect the driver with power.**
Failure to follow this instruction may result in fire.
- 06. Check the control input signal before supplying power to the driver.**
Failure to follow this instruction may result in personal injury or product damage by unexpected driver movement.
- 07. Install a safety device to maintain the vertical position after turn off the power of the driver.**
Failure to follow this instruction may result in personal injury or product damage by releasing holding torque of the motor.
- 08. Use the unit within the rated specifications.**
Failure to follow this instruction may result in fire or product damage.
- 09. Use a dry cloth to clean the unit, and do not use water or organic solvent.**
Failure to follow this instruction may result in fire or electric shock.
- 10. The driver may overheat depending on the environment. Install the unit at the well-ventilated environment and forced cooling with a cooling fan.**
Failure to follow this instruction may result in product damage or degradation by heat.
- 11. Keep the product away from metal chip, dust, and wire residue which flow into the unit.**
Failure to follow this instruction may result in fire or product damage.
- 12. Use the designated motor only.**
Failure to follow this instruction may result in fire or product damage.

Cautions during Use

- Follow instructions in 'Cautions during Use'. Otherwise, it may cause unexpected accidents.
- Power supply should be insulated and limited voltage/current or Class 2, SELV power supply device.
- Re-supply power after 1 sec from disconnected power.
- In case of unwanted noise generating from peripherals and power, use ferrite core in the wiring.
- Keep the distance between power cable and signal cable over 10 cm.
- The thickness of cable should be same or thicker than the below specifications when connecting the cable for connector.
 - Power connector (PWR): AWG18
 - Motor + Encoder connector (MOTOR): AWG22, AWG24
 - I/O connector (SIGNAL I/O): AWG28
 - Brake connector (BRAKE): AWG22
- Motor vibration and noise may occur in a specific frequency range.
 - Change the motor installation method or attach the damper.
 - Use the unit out of the corresponding frequency range due to changing motor RUN speed.
- Maintain and inspect regularly the following lists.
 - Unwinding bolts and connection parts for the unit installation and load connection
 - Abnormal sound from ball-bearing of the unit
 - Damage and stress of lead cable of the unit
 - Connection error with motor
 - Inconsistency between the axis of motor output and the center, concentric (eccentric, declination) of the load, etc.
- This product does not contain a protection function for a motor unit.
- This unit may be used in the following environments.
 - Indoors (in the environment condition rated in 'Specifications')
 - Altitude max. 2,000 m
 - Pollution degree 2
 - Installation category II

Noise Measure

- If there is noise interference caused by motor drive, attach a ferrite core to the cable.
- In particular, USB communication is susceptible to external noise, so attach a ferrite core or separate the ground.

Ordering Information

This is only for reference, the actual product does not support all combinations. For selecting the specified model, follow the Autonics website. Select a model that matches the ordering information of the motor and the driver.

AiC - D - ① ② ③ - ④ - EC

① Frame size

Number: Frame size (mm)

③ Encoder resolution

	□ 20 / 28 / 35 mm	□ 42 / 56 / 60 mm
A	4,000 PPR (1,000 PPR × 4)	10,000 PPR (2,500 PPR × 4)
B	16,000 PPR (4,000 PPR × 4)	-

② Axial length

S: Short
M: Medium
L: Long

④ Motor type

No mark: Standard type
B: Built-in brake type

Product Components

- Product
- Instruction manual
- Power connector × 1
- I/O connector × 1
- Brake connector (AiC-D-B-EC Series) × 1

Manual

For proper use of the product, refer to the manuals and be sure to follow the safety considerations in the manuals. Download the manuals from the Autonics website.

Software

Download the installation file and the manuals from the Autonics website.

■ atMotion

The program allows to manage the motor driver's parameter setting and monitoring data.

Sold Separately

- Power cable: CJ-PW-□
- I/O cable: CO20-MP□-R (specifications: AiC-EC TAG)
- Motor + Encoder cable: C1D14M(B)-□ (fixed type), C1DF14M(B)-□ (flexible type)

Dimensions

- Unit: mm, For the detailed drawings, follow the Autonics website.

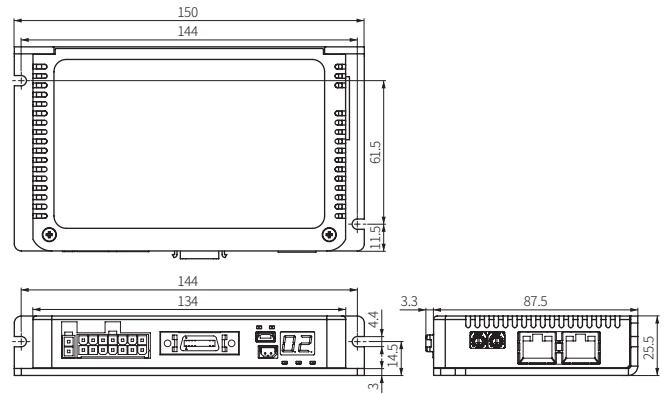

Unit Descriptions

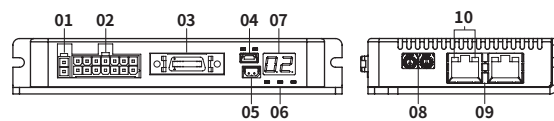

- 01. Power connector**
- 02. Motor + Encoder connector**
- 03. I/O connector**
- 04. USB connector**
- 05. Brake connector (AiC-D-B-EC Series)**
- 06. Status indicators**
- 07. Status display part**
- 08. Comm. ID setting rotary switch**
- 09. Comm. connector**
- 10. Comm. indicator**

Status Display Part / Indicators

Display part / Indicator	Color	Descriptions
Status display part (7-segment)	Red	Displays EtherCAT ID Displays the corresponding number, operation when alarm / warning occurs
Servo ON / OFF indicator (SERVO)	Orange	Turns ON when servo is ON, Turns OFF when servo is OFF
In-Position indicator (INP)	Yellow	Turns ON when motor is placed at command position after positioning input
Power / Alarm indicator (PWR/AL)	Green	Turns ON when the unit operates in normal after power is applied Flashes depending on the warning type
	Red	Flashes depending on the alarm type
EtherCAT comm. status indicator (RUN / ERR)	Green	Turns ON depending on communication normal status (RUN)
	Red	Turns ON depending on communication fail status (ERR)

Alarm / Warning

The status display part displays segment depending on Alarm / Warning type. Depending on the alarm / warning type, it flashes for 0.4 sec interval and it turns OFF for 0.8 sec repeatedly. For more information of Alarm / Warning, refer to 'User manual'.

■ Alarm

Display	Alarm type	Display	Alarm type
C.5	EtherCAT comm. error	E.8	Regenerative voltage error
E.1	Overcurrent error	E.9	Motor alignment error
E.2	Overspeed error	E.R	Input command error
E.3	Position tracking error	E.b	Input voltage error
E.4	Overload error	E.C	In-Position error
E.5	Overheat error	E.d	Memory error
E.6	Motor connection error	E.E	Emergency stop
E.7	Encoder connection error	E.H	Home search error

■ Warning

Display	Warning type
W.1	+Software limit
W.2	-Software limit
W.3	+Hardware limit
W.4	-Hardware limit
W.5	Overload warning

Specifications

Model	AiC-D-20□A-EC	AiC-D-28□B-EC	AiC-D-35□B-EC
Power supply	24 VDC± ±10%		
Max. RUN power ⁽¹⁾	≤ 60 W		
Stop power ⁽²⁾	≤ 10 W		
Max. RUN current ⁽³⁾	0.6 A / Phase	1.0 A / Phase	1.2 A / Phase
Stop current	20 to 100% of max. RUN current		
Basic step angle	1.8° / Phase		
Resolution	500, 1000, 1600, 2000, 3600, 4000, 5000, 6400, 7200, 10000 (factory default) PPR	500, 1000, 1600, 2000, 3600, 5000, 6400, 7200, 10000 (factory default), 16000 PPR	

Model	AiC-D-42□A-□-EC	AiC-D-56□A-□-EC	AiC-D-60□A-□-EC
Power supply	24 VDC± ±10%		
Max. RUN power ⁽¹⁾	≤ 60 W	≤ 120 W	≤ 240 W
Stop power ⁽²⁾	≤ 10 W	≤ 12 W	≤ 15 W
Max. RUN current ⁽³⁾	1.7 A / Phase	3.5 A / Phase	≤ 15 W
Stop current	20 to 100% of max. RUN current		
Basic step angle	1.8° / Phase		
Resolution	500, 1000, 1600, 2000, 3200, 3600, 5000, 6400, 7200, 10000 (factory default) PPR		

01) When changing the load rapidly, instantaneous peak current may increase. The capacity of power supply should be over 1.5 to 2 times of max. RUN power.

02) Based on ambient temp. 25°C, ambient humi. 55%RH, stop current 50%

03) RUN current varies depending on the input RUN frequency and max. RUN current at the moment varies also.

Run method	2-phase bipolar closed-loop control method
Speed filter	Disable, 2, 4, 6, 8, 10, 20, 40, 60 (factory default), 80, 100, 120, 140, 160, 180, 200 ms
Control Gain	0 (factory default) to 15, (15: Fine Gain)
Max. rotation speed	3,000 rpm
In-Position	Fast Response: 0 (factory default) to 7, Accurate Response: 0 to 7
Operation mode	CSP, CSV, PP, PV, HM
Home search	Homing on the negative limit switch and index pulse Homing on the positive limit switch and index pulse Homing on the home switch and index pulse (Positive) Homing on the home switch and index pulse (Negative) Homing without an index pulse (negative limit switch) Homing without an index pulse (positive limit switch) Homing without an index pulse (Positive and Home sensor ON) Homing without an index pulse (Negative and Home sensor ON) Homing on the index pulse (Negative) Homing on the index pulse (Positive) Set the Origin with Home offset Set the Origin and Reset Current Position Torque Homing Search- with Home offset Torque Homing Search+ with Home offset

I/O voltage level	[H]: 5 - 30 VDC±, [L]: 0 - 2 VDC±
Input	Exclusive input: 7, General input: 5
Output	Exclusive output: 2, General output: 4
External power supply	VEX (Default: 24 VDC±), GEX (GND)
Insulation resistance	≥ 100 MΩ (500 VDC± megger)
Dielectric strength	1,000 VAC~ 60 Hz for 1 minute
Vibration	1.5 mm double amplitude at frequency 10 to 55 Hz (for 1 minute) in each X, Y, Z direction for 2 hours
Shock	300 m/s ² (≈ 30 G) in each X, Y, Z direction for 3 times
Ambient temp.	0 to 50°C, storage: -10 to 60°C (no freezing or condensation)
Ambient humi.	35 to 85%RH, storage: 10 to 90%RH (no freezing or condensation)
Protection rating	IP20 (IEC standard)
Approval	CE, RoHS
Unit weight (packaged)	≈ 350 g (≈ 500 g)

Communication Interface

■ EtherCAT

Comm. specifications	EtherCAT
Association approval ⁽¹⁾	EtherCAT
Support protocol	CoE (support CIA402 profile)
Physical layer	100BASE-TX (IEEE802.3)
Connection cable	CAT5e class or over (Shield type: SF/FTP, S/FTP, SF/UTP)
Max. comm. distance	Within 100 m distance between nodes
Baud rate	10 / 100 Mbps
Distributed clock	DC cycle: 250 us, 500 us, 1 ms, 2 ms, 4 ms
Node ID setting	ECAT ID switch setting: 1 to 99 Physical address setting at Master: 1 to 65535
Topology	Star, Line, Tree

01) EtherCAT® is registered trademark and patented technology, licensed by Beckhoff Automation GmbH, Germany.

Troubleshooting

Malfunction	Causes	Troubleshooting
When communication is not connected	The communication cable is not connected.	Check communication cable wiring. Check communication cable connected correctly.
	The communication port or period settings are not correct.	Check communication port and period settings are correct.
	XML file does not match.	Check provided XML file is correct.
When motor does not excite	Servo ON is not.	Check the Hold Off input signal. In case of ON, Servo is OFF and excitation of the motor is released.
	Alarm occurs.	Check the alarm type and remove the cause.
When motor rotates to the opposite direction of the designated direction	Polarity parameter setting is not correct.	Check the Polarity parameter settings.
When motor drives unstable	Connection between motor and encoder is unstable.	Check the driver and motor are connected correctly.
	Control Gain value is not correct.	Change the Control Gain parameter as the appropriate value.

Connectors

■ Power connector (PWR)

Pin	Function
1	24VDC±
2	GND

■ Motor + Encoder connector (MOTOR)

Pin	Function	Pin	Function
1	GND	8	+5 VDC±
2	Encoder A	9	Encoder \bar{A}
3	Encoder B	10	Encoder \bar{B}
4	Encoder Z	11	Encoder \bar{Z}
5	PE	12	N·C
6	Motor A	13	Motor B
7	Motor \bar{A}	14	Motor \bar{B}

■ I/O connector (SIGNAL I/O)

Pin	Function	Pin	Function
1	VEX	11	IN3
2	ORG	12	IN4
3	+Limit	13	IN5
4	-Limit	14	In-Position
5	Alarm Reset	15	Alarm
6	Hold Off	16	OUT1
7	Stop	17	OUT2
8	EMG	18	OUT3
9	IN1	19	OUT4
10	IN2	20	GEX

■ USB connector (COM)

Pin	Function	Pin	Function
1	V BUS	4	N·C
2	Data -	5	GND
3	Data +	-	-

■ Brake connector (BRAEK)

• Only available in built-in brake type.

Pin	Function
1	GND
2	24VDC±

■ EtherCAT communication connector (ECAT IN / ECAT OUT)

Pin	Function	Pin	Function
1	TD+	5	N·C
2	TD-	6	RD-
3	RD+	7	N·C
4	N·C	8	N·C

■ Suitable specifications

- The following connectors can be used with equivalent or substitute.
- EtherCAT dedicated cable must be used and the performance can not be guaranteed when using other cables.

Type	Connector specifications	Manufacture
PWR	Power connector CHD1140-02, connector terminal: CTD1140	HANLIM
MOTOR	Motor + Encoder connector 5557-14R, connector terminal: □ 20 / 28 / 35 mm: 5556T2 □ 42 / 56 / 60 mm: 5556T	Molex
SIGNAL I/O	I/O connector 10120-3000PE, housing: 10320-52F0-008	3M
COM	USB connector Mini USB Type B	-
BRAKE	Brake connector 5264-02, connector terminal: 5263PBT	Molex
ECAT IN	EtherCAT comm. connector	-
ECAT OUT	RJ45	-

Switch

■ Communication ID setting rotary switch (SW201, SW200)

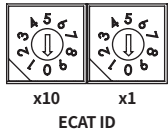

Setting	Address (×10)	Address (×1)
0	0×10	0
1	1×10	1
2	2×10	2
3	3×10	3
4	4×10	4
5	5×10	5
6	6×10	6
7	7×10	7
8	8×10	8
9	9×10	9

Connections

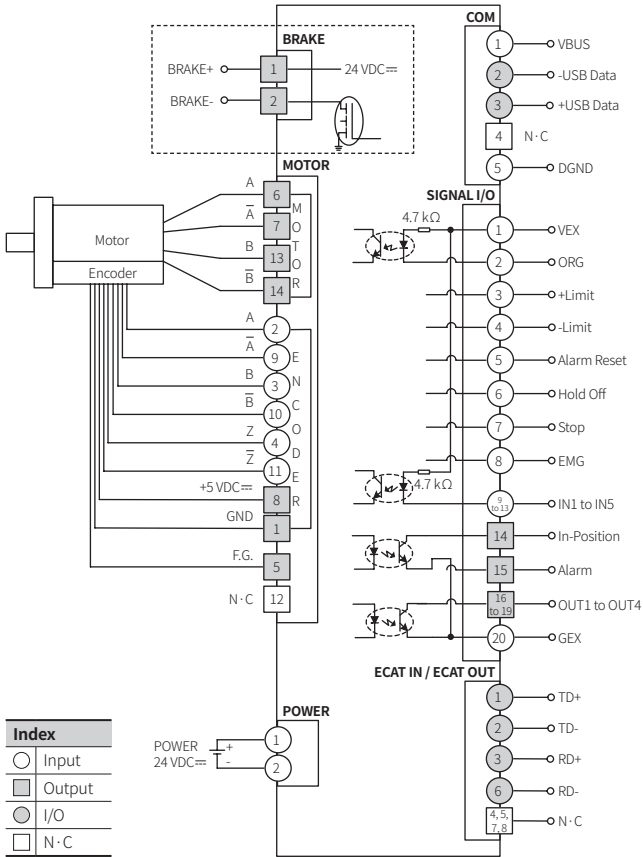

Index	
○	Input
◻	Output
⊙	I/O
□	N·C

• ⊙ is only available in built-in brake type.

Sold Separately : Power Cable

■ CJ-PW-□

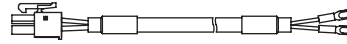

- Recommended to use ferrite core at both ends of the cable.
- The model name is 010, 020 which indicates the cable length.
E.g.) CJ-PW-010: 1 m power cable

Sold Separately : Motor + Encoder Cable

■ Fixed type: C1D14M-□, Flexible type: C1DF14M-□

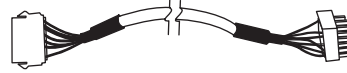

- Recommended to use ferrite core at both ends of the cable.
- The model name is 1, 2, 3, 5, 7, 10, 15, 20 which indicates the cable length.
E.g.) C1DF14M-10: 10 m flexible type Motor + Encoder cable
- For built-in brake type, use dedicated cable.
(fixed type: C1D14MB-□, flexible type: C1DF14MB-□)

Sold Separately : I/O Cable

■ CO20-MP□-R (Specifications: AiC-EC TAG)



Pin	Function (Name TAG)	Cable Color	Dot line color-number
1	VEX	Yellow	Black-1
2	ORG		Red-1
3	+Limit		Black-2
4	-Limit		Red-2
5	Alarm Reset		Black-3
6	Hold Off		Red-3
7	Stop		Black-4
8	EMG		Red-4
9	IN1	White	Black-5
10	IN2		Red-5
11	IN3		Black-1
12	IN4		Red-1
13	IN5		Black-2
14	In-Position		Red-2
15	Alarm		Black-3
16	OUT1		Red-3
17	OUT2		Black-4
18	OUT3		Red-4
19	OUT4		Black-5
20	GEX		Red-5

- Recommended to use ferrite core at both ends of the cable.
- The model name is 010, 020, 030, 050, 070, 100, 150, 200 which indicates the cable length.
E.g.) CO20-MP070-R: 7 m I/O cable